

Fox Hole™

Unbeatable portability, limitless possibilities.

The Fox Hole is a system of modular panels and brackets designed to provide soldiers with an area of ballistic and blast-fragment protection. Ideal for use by fielded marine and army units, the Fox Hole's ease of transport and assembly make it a simple and effective alternative to traditional sand bag or in-ground bunkers.

Fox Hole panels are 4 feet tall and available in 2- and 4-foot widths. Connecting brackets are available in 0, 30, 45 and 90 degree angles, allowing for custom configuration to fit specific requirements. The unit is available as NIJ Level III Rifle Resistant or NIJ Level IV Armor-Piercing Resistant, weighing 15 pounds and 20.5 pounds per square foot, respectively.

Safety with versatility

Smaller, lighter and more portable than most protective systems, the Fox Hole breaks down quickly and can be established in a new location with ease. All assembly of the unit can be completed in the field with no tools, and a three-panel system takes approximately ten minutes for two people to assemble.

A number of custom features and options help maximize the Fox Hole's effectiveness in the field:

- Components feature a durable, anti-corrosion, powder-coated finish
- Weapon access ports are available
- Camography™, a customizable photo laminate, is available to add camouflage to the units
- Available as an individual solution or as part of the Sentry Protection System (SPS)

Specifications

| | |
|----------------------|---|
| Product Name: | Fox Hole |
| Description: | Modular ballistic/blast wall |
| Protection: | Up to NIJ Level IV |
| Weight: | NIJ III ~ 15 lbs/ft ² NIJ IV ~ 20.5 lbs/ft ² |

Sentry Protection System (SPS)

While the Fox Hole is a useful defensive tool on its own, its effectiveness and the safety of your troops and personnel can be maximized when it is used as part of the Sentry Protection System. The SPS combines the Fox Hole with Defenshield's RPG Wall and MDFP units to create an area of maximum security.

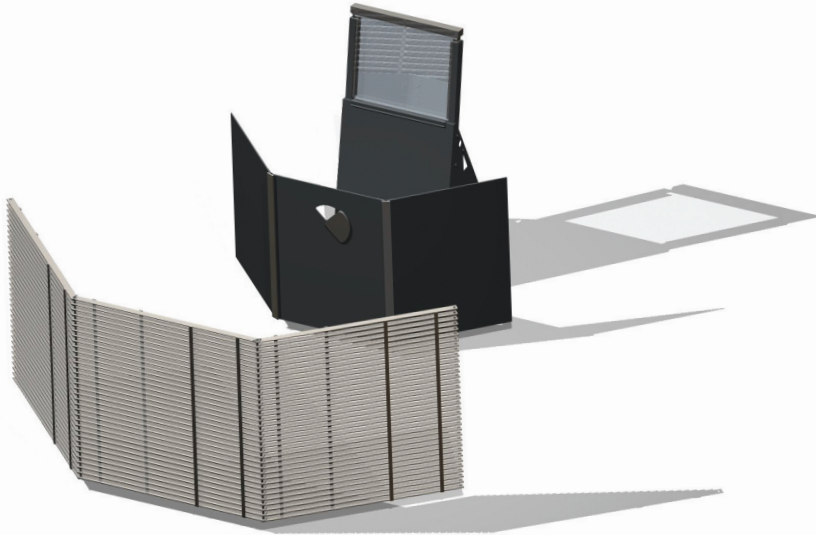

With the SPS, soldiers are protected on all levels, from bullet and blasts to RPGs and other anti-armor munitions. In addition, the SPS affords a combination of visibility and portability that you won't find in any other defense system.

Defenshield, Inc.

Defenshield, Inc. is a veteran-owned, SBA-certified small business manufacturing bullet, blast and fragment resistant equipment for the government, military, law enforcement, and the private sector for anti-terror, force protection, and physical security requirements. Defenshield products are currently saving the lives of a diverse range of customers around the world.

“Good News for Good Guys”™

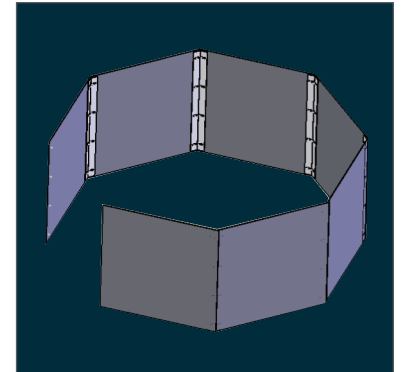

Several connected panels create a bunker with nearly 360 degrees of ballistic protection.



Ballistic data, photographs and video footage are available online at: www.defenshield.com